



FRAGUA CHAIR 02

Fragua presents a triad of experimental and sculptural chairs. This series showcases three chairs with different backrests; in the shape of a circle, a rectangle and a triangle. Creating a minimalistic and brutalist approach to its geometric form and composition.

Named after the word "Fragua" which in Spanish means forge; a heritage of traditional metallurgical crafts. Inspired by an observational study on the relationship between earth and fire, we envision Fragua as a portal where materials transcend into sculpture through fire and artisanship.

MATERIALS

Stainless Steel
Fabric

DIMENSIONS

(L) 450mm

(W) 450mm

(H) 820mm

TOP

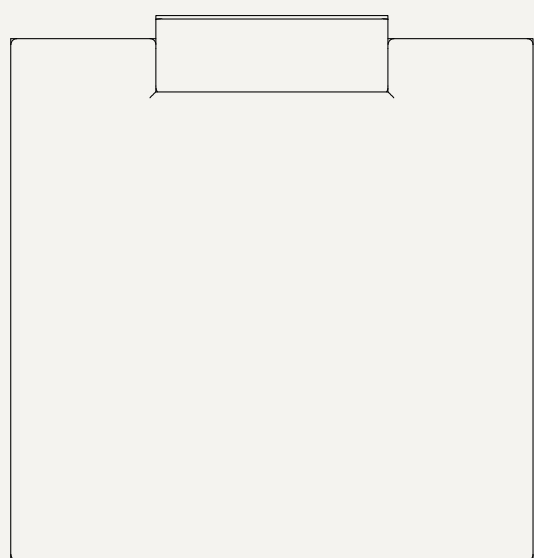

PERSPECTIVE

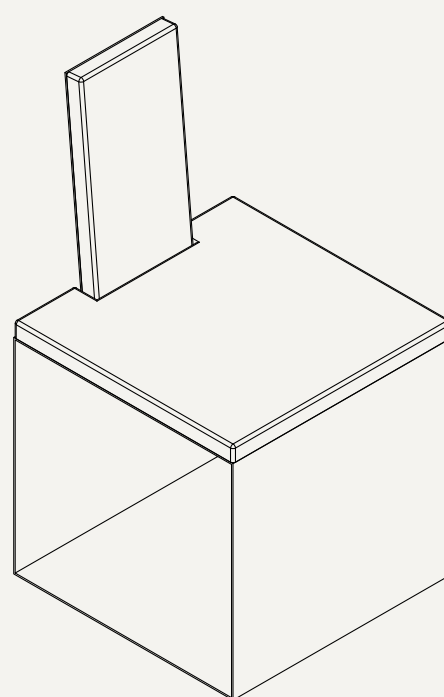

FRONT

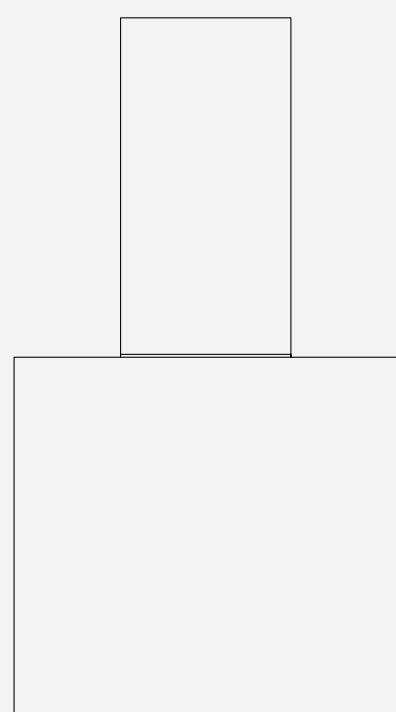

RIGHT

